



32cd Low-intensity Obstruction Light

115V_{AC} ICAO Type B - FAA L-810 - replacement unit

CEL-32-115-E27

Key features

- Based on LED technology
- Extremely reliable - long lifetime
- Very low power consumption
- 115VAC nominal supply voltage
- Intensity more than 32cd
- Stabilised light output
- Easy to install
- No RF-radiations

Benefits

- Long maintenance intervals
- Low energy cost
- Supply power voltage variations do not affect light output
- Very low total lifetime costs
- Comes with five (5) years warranty

Specifications met

- ICAO International Standards and Recommended Practices: Aerodromes - Annex 14 Volume 1, 5th Edition, July 2009, Chapter 6: Low-intensity, Type B Fixed Obstacle Light
- FAA Advisory Circular 150/5345-43F 09/12/06 L-810 Light Unit

Optical characteristics

- Intensity >32cd
- Colour aviation red
- Horizontal radiation pattern 360°
- Vertical radiation pattern 50°
- LED supply current stabilised by constant current generator
- Light output degradation less than 30% after 100,000hrs of operation

Electrical characteristics

- LEDs in several separate groups
- Nominal operating voltage 115V_{AC}
- Power consumption less than 15VA
- Operating voltage range 105 to 140V_{AC}
- Two-stage over-voltage protection

Mechanical characteristics

- Yellow ABS body
- Ingress protection IP30
- Operating temperature range -55°C to +55°C
- Height 110mm, diameter 92mm, weight 0.4kg

Order Code: CEL-32-115-E27

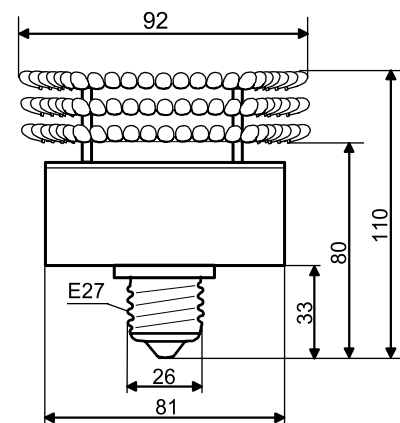

CEL-32-115-E27



T: +44 (0)20 8540 1034
F: +44 (0)20 8543 3058
E: info@contarnex.com

Contarnex Europe Limited
252 Martin Way,
Morden, Surrey SM4 4AW
United Kingdom

